

低温涡旋套机：



产品简介：

低温涡旋套机选用谷轮低温喷气增焐压缩机，R404A冷媒预充注，适用库温+5°C到-30°C。
 标准机组名义功率3~15HP。
 全系列标配智能控制器，故障诊断，EVI双电子膨胀阀和完善的系统保护。
 可另配的无线远程模块，拓展了客户新的使用方式。特殊型号和应用可定制。







配置说明：

- EVI双电子膨胀阀模糊控制
- 智能按需热气化霜
- 全功能智能控制器
- 智能风机调速
- 油份/气分+经济器+双排足换热量冷凝器+高品质压力传感器
- 冷媒预充注 (R404A)
- 标准安装，精确调试
- 全系列4.5片距标准风机/不含翅片化霜电加热



制冷量及功耗 (千瓦) Cooling Capacity and Power (KW)				R404A / 50 Hz											
型号 Model	压缩机 Compressor	冷凝温度°C Condensing Temperature	蒸发温度°C Evaporating Temperature												
			-40	-35	-30	-25	-20	-15	-10	-5	0	5	7		
3HP LT 	CCUC-030ASGL	V*130KQE	制冷量 (瓦) Cooling Capacity (Watts)	30	2.60	3.23	3.95	4.75	5.66	6.70	7.88	9.15	10.54	12.04	12.64
				40	2.51	3.10	3.76	4.52	5.41	6.42	7.58	8.93	10.43	12.08	12.79
				50	2.21	2.81	3.51	4.21	5.04	6.02	7.17	8.51	8.51	11.81	12.60
			耗电量 (瓦) Power (Watts)	30	1.58	1.63	1.68	1.74	1.80	2.03	2.08	2.11	2.12	2.09	2.07
				40	1.99	2.02	2.07	2.12	2.19	2.47	2.54	2.58	2.61	2.62	2.61
				50	2.25	2.60	2.63	2.66	2.72	3.05	3.11	3.16	3.20	3.22	3.22
5HP LT 	CCUC-050ASGL	V*161KQE	制冷量 (瓦) Cooling Capacity (Watts)	30	3.90	4.80	5.82	6.98	8.33	11.20	11.85	13.80	15.85	18.04	19.35
				40	3.85	4.64	5.57	6.65	7.91	10.70	11.44	13.43	15.60	17.82	19.09
				50	3.78	4.52	5.28	6.26	7.42	9.16	10.80	12.75	15.04	17.60	18.76
			耗电量 (瓦) Power (Watts)	30	2.35	2.47	2.59	2.70	2.81	3.02	3.16	3.22	3.31	3.40	3.44
				40	2.80	2.96	3.11	3.26	3.39	3.70	3.75	3.86	3.98	4.07	4.10
				50	3.42	3.62	3.81	3.98	4.14	4.45	4.60	4.64	4.80	4.90	4.93
8HP LT 	CCUC-080ASGL	ZFI36KQE	制冷量 (瓦) Cooling Capacity (Watts)	30	6.52	8.06	9.85	11.85	14.10	16.35	19.15	22.20			
				40	6.31	7.73	9.41	11.35	13.50	15.65	18.40	21.60			
				50	6.11	7.50	8.85	10.6	12.65	14.7	17.40	20.60			
			耗电量 (瓦) Power (Watts)	30	3.60	3.85	4.09	4.32	4.54	4.86	5.02	5.18			
				40	4.22	4.61	4.96	5.27	5.54	5.86	6.05	6.23			
				50	4.89	5.45	5.95	6.38	6.75	7.14	7.36	7.56			
10HP LT 	CCUC-100ASGL	ZFI50KQE	制冷量 (瓦) Cooling Capacity (Watts)	30	8.94	11.05	13.35	16.00	18.95	22.40	26.20	30.40			
				40	8.62	10.60	12.80	15.35	18.20	21.40	25.20	29.50			
				50	7.99	9.59	12.10	14.45	17.15	20.10	23.80	28.10			
			耗电量 (瓦) Power (Watts)	30	4.81	5.20	5.54	5.85	6.13	6.64	6.87	7.08			
				40	5.77	6.21	6.60	6.96	7.31	8.01	8.28	8.52			
				50	6.94	7.43	7.87	8.29	8.69	9.77	10.05	10.35			
13HP LT 	CCUC-130ASGL	ZFI59KQE	制冷量 (瓦) Cooling Capacity (Watts)	30	11.05	13.65	16.55	19.80	23.5	27.10	31.70	36.80			
				40	10.70	13.10	15.85	19.00	22.5	25.90	30.50	35.80			
				50	9.90	11.87	15.00	17.90	21.3	24.30	28.80	34.00			
			耗电量 (瓦) Power (Watts)	30	5.96	6.44	6.86	7.24	7.60	8.04	8.31	8.57			
				40	7.15	7.69	8.18	8.63	9.06	9.70	10.00	10.30			
				50	8.60	9.21	9.76	10.25	10.75	11.85	12.20	12.50			
15HP LT 	CCUC-150ASGL	ZFI68KQE	制冷量 (瓦) Cooling Capacity (Watts)	30	12.55	15.50	18.80	22.50	26.60						
				40	12.10	14.90	17.50	21.50	25.50						
				50	11.23	13.46	17.00	20.30	24.10						
			耗电量 (瓦) Power (Watts)	30	6.93	7.49	7.98	8.42	8.84						
				40	8.31	8.94	9.51	10.05	10.55						
				50	10.00	10.71	11.35	11.95	12.50						

低温涡旋套机技术参数：

型号	名义功率	3HP低温套机	5HP低温套机	8HP低温套机	10HP低温套机	13HP低温套机	15HP低温套机
	室外机	CCUC-030ASGL	CCUC-050ASGL	CCUC-080ASGL	CCUC-100ASGL	CCUC-130ASGL	CCUC-150ASGL
	室内机	CAE-150/351R45A	CAE-250/352R45A	CAE-600/452R45A	CAE-600/452R45A	CAE-1050/502R45A	CAE-1050/502R45A
							
适用库温		℃					
电源规格		380V/3N~ /50Hz					
制冷剂		预充注R404A					
控制方式		智能按需热气化霜，双电子膨胀阀模糊控制，经济器+油分+气分+压力传感器，风机调速，全功能电箱控制器，液晶温度手操器，等功能					
节流方式		双电子膨胀阀+经济器					
压缩机	型式	全封闭涡旋					
	系列	V*130	V*161	谷轮ZFI36	谷轮ZFI50	谷轮ZFI59	谷轮ZFI68
冷凝风机	类型	低噪音6级内转子风机					
	风机数量x功率	PCSxW	1x60	2x60	1x250	2x250	2x250
	风机直径	mm	450	450x2	560	560x2	560x2
冷风机 (内机)	出风方式	侧吹风					
	风机(直径x数量)	mmxN	300x2	300x3	450x2	450x2	500x2
	风机电压	v	220	220	380	380	380
	风机射程	m	10	10	15	15	20
	翅片间距	mm	4.5	4.5	4.5	4.5	4.5
	冷却面积	m ²	15.5	25	60	60	105
	风量	m ³ /h	975x2	975x3	4280x2	4820x2	4923x2
	空气射程	m	13	13	13	13	13
	输入功率	W	72x2	72x3	290x2	290x2	423x2
	脱水盘防冻电加热	W	900	1200	1200	1200	1400
	冷媒进出管	mm	Φ12.7/Φ15.88	Φ12.7/Φ19.05	Φ19.05/Φ28.58	Φ19.05/Φ28.58	Φ22.22/Φ34.93
	外形尺寸	mm	1280x420x475	1580x420x475	1520x620x700	1520x620x700	1920x620x710
	吊顶安装尺寸	mm	1060x340	1365x340	610x640+510	610x640+510	840x810+510
排水管接口	inch	G 1"	G 1"	G 1"	G 1"	G 1"	
连接规格	液管	mm	Φ12.7	Φ12.7	Φ19.05	Φ19.05	Φ22.22
	气管	mm	Φ15.88	Φ19.05	Φ28.58	Φ28.58	Φ34.93
噪音	室外机	dB(A)	58	58	60	62	62
	室内机	dB(A)	60	60	65	65	68
外机尺寸	室外机 长x深x高	mm	1034x424x845	1027x424x1248	800x753x1005	1460x801x1001	1460x801x1001
	外机安装尺寸	mm	700x388	580x388	530x771	1126x774	1126x774
机器重量	室外机	kg	85	120	180	220	250
	室内机	kg	30	45	70	70	96

外形尺寸图

机组（内机）外形尺寸

3HP机组

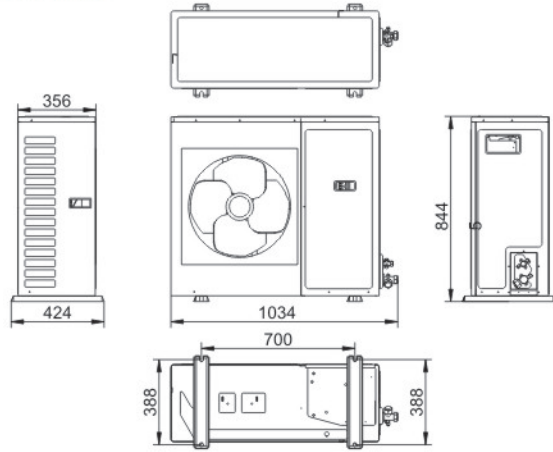

5HP机组

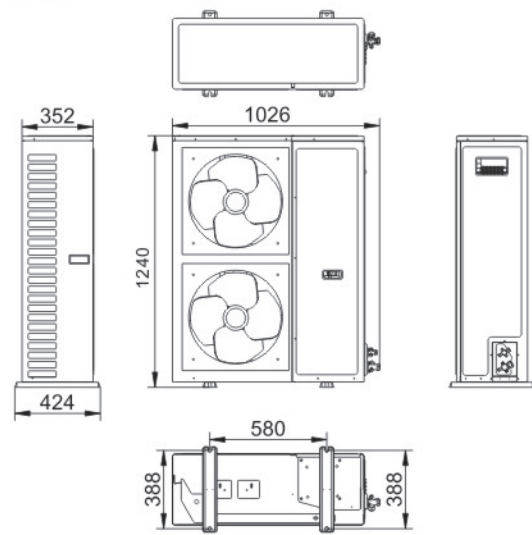

8HP机组

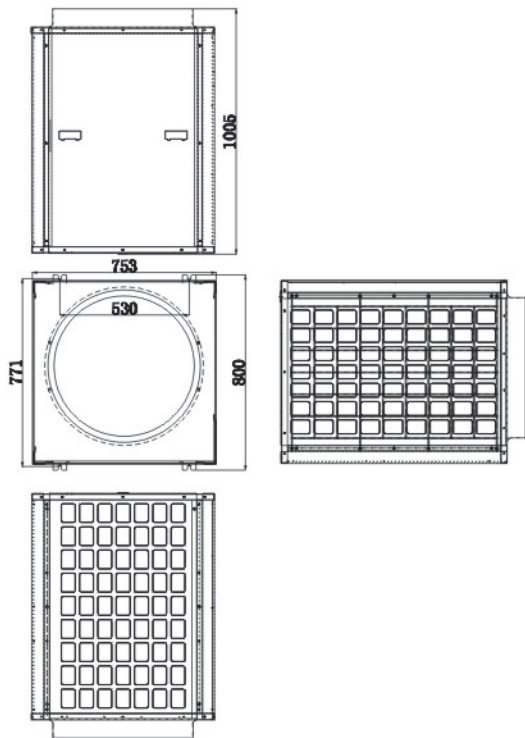

10/13/15HP机组

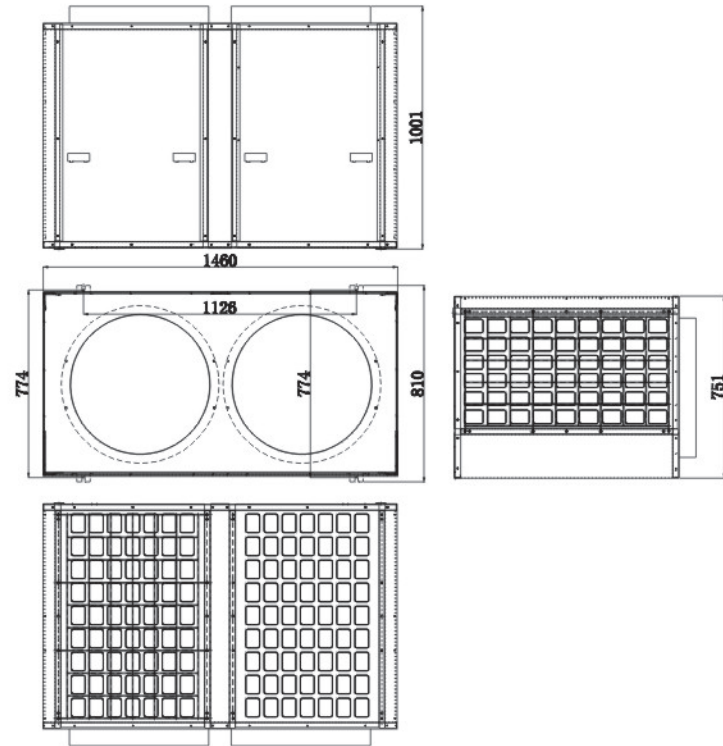

冷风机（外机）外形尺寸

3HP风机

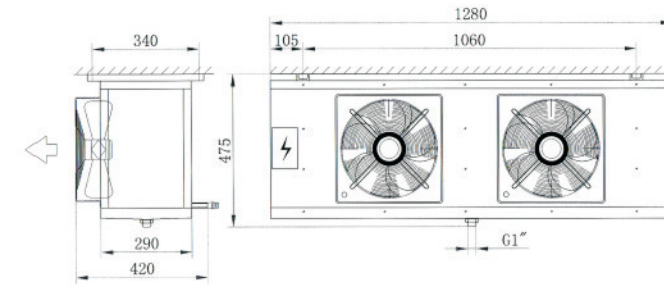

5HP风机

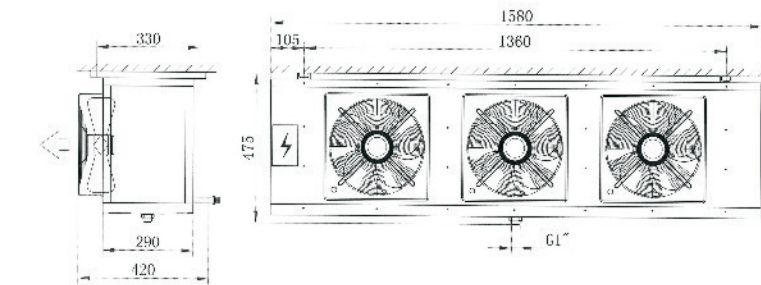

8/10HP风机

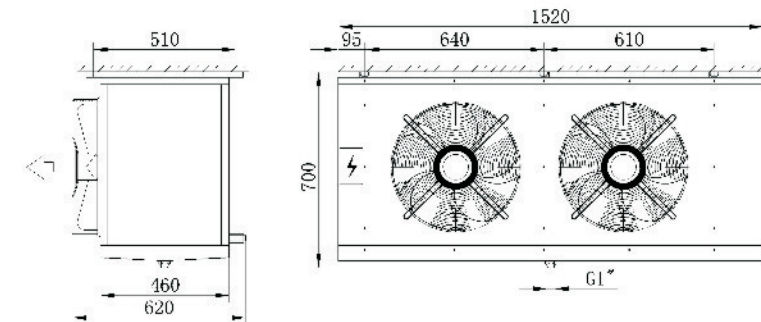

13/15HP风机

